

# nyloprint® Flowline Washer DWT 100

Compact, tankless flowline system for  
washout, drying and post exposure

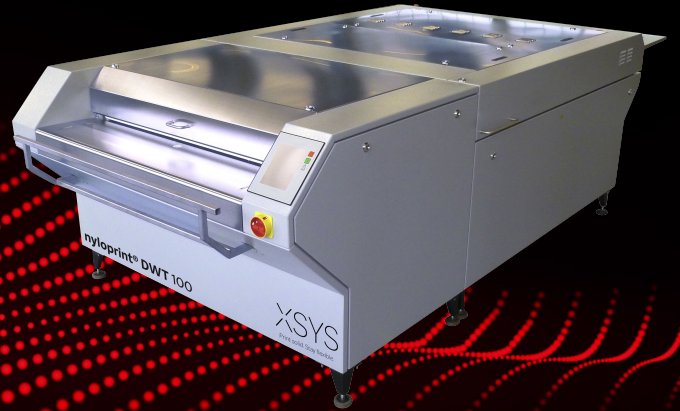

**Large-size flowline combination, suitable for processing water washable printing plates  
up to a maximum width of 1000 mm (39.4")**

## **High productivity and reliability due to superior construction**

- + Flowline system with optimal design for processing water washable printing plates – washout, rinsing, drying and UV-A post exposure all made automatically in line
- + Less mechanical stress due to a proven “push” system that prevents washing away the fine elements
- + Water temperature indicator and flowspeed control
- + Direct water supply to reduce the contamination level in the washout section, thus reducing downtime due to maintenance cleaning
- + Automatic lowering of squeegee roller
- + Excellent quality offering a long service life

## **Simple operation and convenient handling**

- + Simple operation due to a touch screen display
- + Single person operating system
- + Two easily adjustable push carriers
- + Runs quietly during operation

## **Further components**

- + Includes an “adhesive” carrier plate for processing foil based plates and a “magnetic” carrier plate for steel based plates
- + Optional brushes and a soft squeegee roller available for special applications

# nyloprint® Flowline Washer DWT 100

## Equipment Dimensions

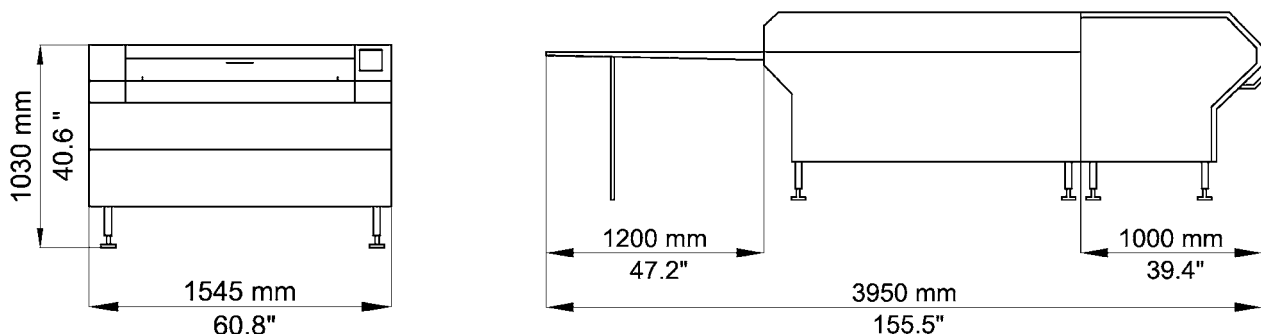

### Technical data

### nyloprint® Flowline Washer DWT 100

Maximum plate width	1000 mm (39.4")
Electrical connection	400 V, 50/60 Hz, 3 P/N/PE (special voltage with sep. transformer)
Nominal current	12 A
Nominal power	8 kW
Fresh water connection	R ½", 2 - 4 bar (29 - 58 PSI)
Fresh water consumption	flow rate 0.8 m³/h (0.47 CFM) at 30 °C (86 °F)
Waste water connection	Ø 40 mm (1.6")
Compressed air connection	G ¼", 6 bar (87 PSI), approx. 200 l/min (7.1 CFM), waterfree
Exhaust air connection	Ø 50 mm (2.0")
Exhaust air flow rate	50 Nm³/h (30 CFM) (approx.)
Transport speed	40 - 350 mm/min (0.13 - 1.15 ft/min)
Tube type UV-A	6 pcs., 60W TL10R
Heating capacity of dryer	6 kW
Weight (approx.)	600 kg (1323 lbs) net 1000 kg (2205 lbs) gross, transformer for special voltage: 170 kg (375 lbs)
Crate dimensions (W x D x H)	3300 mm x 2100 mm x 1500 mm (129.9" x 72.8" x 59.1") Transformer for special voltage: 880 x 680 x 890 mm (34.7" x 26.8" x 35.0")

### Important remark on water supply:

A temperature controlled mixing tap is required if hot and cold water is available.  
An electronically controlled flow heater is required if only cold water is available.

### Please contact us for additional information.

info@xsyglobal.com • www.xsyglobal.com

The aim of our technical documents is to inform and advise our customers. The information provided herein is correct to the best of XSYS's knowledge. No liability for any errors, facts or opinions is accepted. Customers must satisfy themselves as to the suitability of this product for their application. No responsibility for any loss as a result of any person placing reliance on any material contained herein will be accepted. Product names followed by ® are trademarks registered by XSYS Germany GmbH and/or its affiliates.

