

nyloprint[®] Combination CW 50x70

Compact all-in-one letterpress plate making system with exposure, washout and drying functions



Largest of the equipment combinations, suitable for processing water washable printing plates up to a maximum size of 500 mm x 700 mm (19.7" x 27.6")

High efficient and cost effective

- + Exposure, washout and drying unit for the production of high quality water washable letterpress plates
- + Space saving as all units can neatly be stacked on a trolley base
- + Available and useable as separate components with own electrical connection - allows to easily replace or upgrade one part of the system if necessary
- + Long service life due to advanced materials - all parts in contact with water are made of high quality stainless steel
- + Process safety due to programmed plate processing parameters and temperature controlled washout section
- + For washout only tap water is needed
- + Less mechanical stress due to a proven plush washout system that prevents the washing away of fine elements
- + Oscillating plate holder ensures even plate washout and is self adjusting to allow the use of different plate thicknesses

Simple operating and convenient handling

- + Digital programmable operating panels for customising the processing times of each function
- + Audio alarm to signal end of each process
- + Trolley base with casters for easy movement and access to the system

nyloprint® Combination CW 50x70

Equipment Dimensions

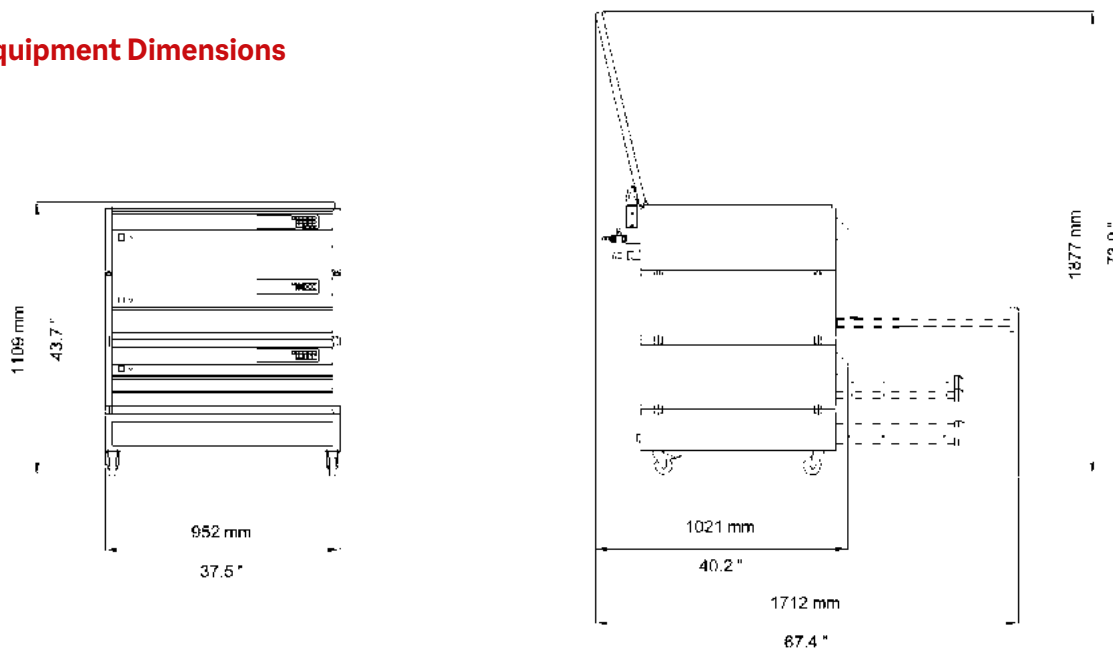

Technical data	Exposure Art. XG10-0004-0114	Washer Art. XG10-0006-0116	Dryer Art. XG10-0005-0114	Trolley Art. XG10-0029-0112
Max. plate size (W x L)	500 mm x 700 mm (19.7" x 27.6")			
Electrical connection	230 V, 50 Hz (1 Ph/N/PE) 230 V, 60 Hz (1 Ph/N/PE)	230 V, 50/60 Hz (1 Ph/N/PE)	230 V, 50/60 Hz (1 Ph/N/PE)	230 V / 400 V (AC)
Nominal current	2.2 A / 2.8 A	13.6 A	4.2 A	-
Nominal power	1.0 kW	3.2 kW	1.2 kW	5.4 kW
Tube type UV-A	40 W, TL 10R	-	-	-
Fresh water connection	-	R ½"	-	-
Waste water connection	-	Ø 25 mm (0.984")	-	-
Dryer	-	-	2 drawers, heating element 2 x 500 W	-
Weight (approx.)	90 kg (198 lbs) net 142 kg (313 lbs) gross	85 kg (187 lbs) net 137 kg (302 lbs) gross	75 kg (165 lbs) net 127 kg (280 lbs) gross	38 kg (84 lbs) net 56 kg (123 lbs) gross
Crate dimensions (W x D x H)	1180 X 1080 X 520 mm (46,5" x 41,3" x 20,5")	1180 X 1080 X 520 mm (46,5" x 41,3" x 20,5")	1180 X 1080 X 520 mm (46,5" x 41,3" x 20,5")	982 x 860 x 495 mm (38.7" x 33.9" x 19.5")

Please contact us for additional information.

info@xsyglobal.com • www.xsyglobal.com

The aim of our technical documents is to inform and advise our customers. The information provided herein is correct to the best of XSYS's knowledge. No liability for any errors, facts or opinions is accepted. Customers must satisfy themselves as to the suitability of this product for their application. No responsibility for any loss as a result of any person placing reliance on any material contained herein will be accepted. Product names followed by ® are trademarks registered by XSYS Germany GmbH and/or its affiliates.



XSYS
Print solid. Stay flexible.