

# No solvents. No waiting. No worries.

**nyloflex<sup>®</sup>**  
**Xpress**  
Thermal Processing System

## nyloflex<sup>®</sup> Exposure F IV ECLF

Combined exposure and light finisher unit with reduced footprint and efficient design



### Exposure section

- + Integrated bed chiller allows for uniform and consistent temperature without limiting exposure times
- + High concentration of UV-A lamps to ensure the highest UV output
- + Fibre optic to detect defective lamps
- + Air flow cooling system for exposure lamps with temperature control
- + Stores up to 24 different process conditions

### Light finishing section

- + One-drawer UV-A / UV-C post exposure and light finishing system
- + Includes air flow cooling system
- + Fibre optic to detect defective lamps

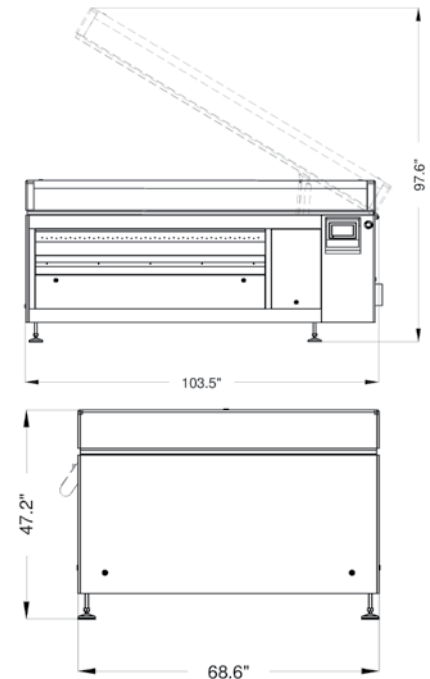

### Technical data

### nyloflex<sup>®</sup> Exposure F IV ECLF

Art. XG50-0004-V103

Maximum plate size (W x L)	1200 mm x 1600 mm (47" x 63")
Electrical connection	400 V, 50/60 Hz (3 Ph/N/PE) 230 V, 50/60 Hz (3 Ph/PE)
Nominal current	at 400 V: 15A at 230 V: 25A
Nominal power	9.5 kW
Compressed air	Min. 102 PSI (7 bar)
Exhaust air flow rate	Min. 590 CFM (1000 m <sup>3</sup> /h)
Weight	gross: 1400 kg (3090 lbs) net: 1120 kg (2472 lbs)
Crate dimensions (W x D x H)	2930 mm x 1930 mm x 1590 mm (116" x 76" x 63")

Please contact us for additional information.

info@xsyglobal.com • www.xsyglobal.com

The aim of our technical documents is to inform and advise our customers. The information provided herein is correct to the best of XSYS's knowledge. No liability for any errors, facts or opinions is accepted. Customers must satisfy themselves as to the suitability of this product for their application. No responsibility for any loss as a result of any person placing reliance on any material contained herein will be accepted. Product names followed by ® are trademarks registered by XSYS Germany GmbH and/or its affiliates.



**XSYS**  
Print solid. Stay flexible.

04-2023